

## The Domino Multicomponent Allylation Reaction for the Stereoselective Synthesis of Homoallylic Alcohols

LUTZ F. TIETZE,\* TOM KINZEL, AND C. CHRISTIAN BRAZEL

*Institut für Organische und Biomolekulare Chemie der Georg-August-Universität  
Göttingen, Tammannstrasse 2, D-37077 Göttingen, Germany*

RECEIVED ON JULY 29, 2008

### CON SPECTUS

**S**tereoselective allylations of carbonyl compounds such as aldehydes and ketones are useful but challenging reactions in organic chemistry. The resulting chiral secondary and tertiary homoallylic alcohols or ethers are valuable building blocks in the synthesis of biologically active natural compounds and pharmaceuticals.

Although researchers have developed several methods for the facially selective allylation of aldehydes, the stereoselective allylation of ketones still poses a severe problem. We have developed a highly diastereoselective domino multicomponent allylation reaction of a ketone and allyltrimethyl silane using the trimethylsilyl ether of a norpseudoephedrine or mandelic acid derivative as an auxiliary with a diastereoselectivity of up to 98:2. The reaction is performed at  $-78\text{ }^{\circ}\text{C}$  in the presence of a catalytic amount of trifluoromethanesulfonic acid and leads to the corresponding tertiary ethers. The procedure can also be used for the allylation of aliphatic aldehydes with a diastereomeric ratio  $>99:1$ . Ketones give the 4,1'-syn product while the aldehydes give the reversed selectivity to yield a 4,1'-anti product. In addition, the reaction of  $\gamma$ -substituted allyl silanes with ketones yields a product with two stereogenic centers and an anti diastereoselectivity of  $>99:1$ .

The homoallylic ethers formed in the domino multicomponent process can be used in further synthetic transformations: the auxiliary can serve as a protecting group or can be cleaved reductively to give the corresponding homoallylic alcohols. Based on a number of both experimental and theoretical studies of the reaction mechanism, we conclude that an intermediate oxocarbenium ion is formed in the reaction of ketones. The oxocarbenium ion is attacked by the allyl silane during the stereogenic step. Using density functional theory methods, we could trace the observed stereoselectivity phenomena back to open transition states (TSs) where there is no interaction between the silane's trimethylsilyl group and the former carbonyl oxygen. On the contrary, the reaction with aldehydes forms an intermediate oxazolidinium salt, which explains the opposite selectivity. We have used the new allylation procedure in several total syntheses of natural products such as vitamin E, (+)-hydroxymyoporone, 5,6-dihydrocineromycin B, and polyoxygenated cembrene.

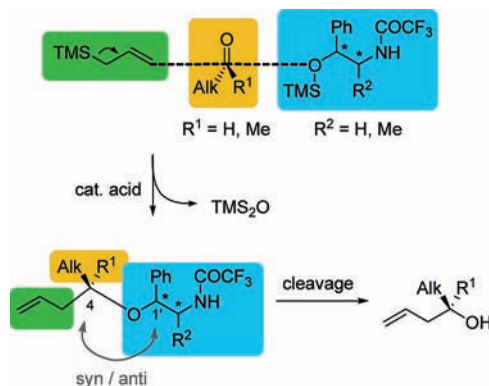

### Introduction

Stereoselective allylations of carbonyl compounds like aldehydes and ketones are very useful but challenging synthetic transformations in organic chemistry.<sup>1</sup> They provide an approach to valuable chiral secondary and tertiary homoallylic alcohols or ethers, which can be used as building blocks in the synthesis of biologically active natural com-

pounds and pharmaceuticals.<sup>1</sup> Hence, several methods<sup>1a</sup> have been developed for the stereoselective allylation of carbonyl compounds. Among others, the domino multicomponent allylation reaction (MCAR)<sup>2</sup> of a carbonyl compound, allyltrimethylsilane, and a trimethylsilyl ether in the presence of a catalytic amount of a Lewis or Brønsted acid is one of the most versatile procedures.<sup>3</sup>

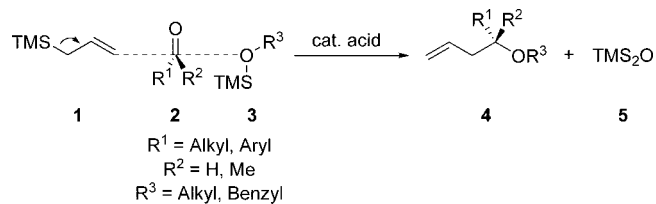
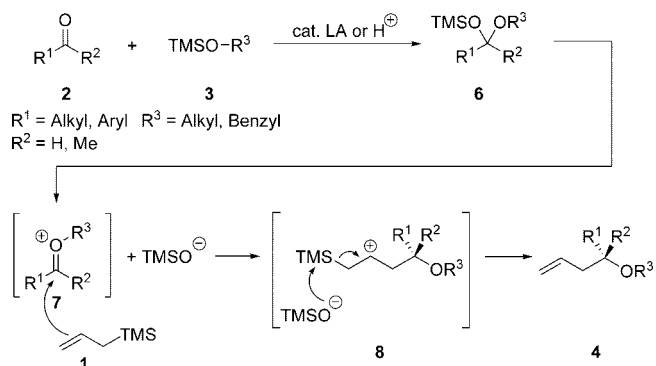
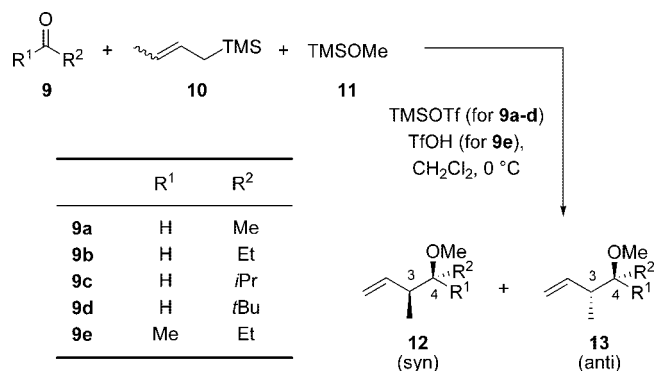
**SCHEME 1.** Schematic Description of the Domino Multicomponent Allylation Reaction (MCAR)**SCHEME 2.** Proposed Mechanism of the MCAR**SCHEME 3.** Crotylation of Aldehydes **9a–d** and Ketone **9e** with *E*- or *Z*-Crotyl Silane (**10**)

Formally, the oxygen atom of the carbonyl compound **2** is replaced by an allyl and an ether moiety, stemming from the employed trimethylallyl silane **1** and the silyl ether **3**, respectively, and TMS<sub>2</sub>O (**5**) is formed as a second product (Scheme 1).

Experimental observations indicate that the mechanism of the MCAR proceeds via a mixed acetal species **6**, which is transformed into an oxocarbenium ion **7** bearing the organic part of the silyl ether residue at its oxygen atom (Scheme 2).<sup>4</sup> Intermediate **7** is then intercepted by the weak nucleophile trimethylallyl silane (**1**) to give the carbenium ion **8**, which in the following step is attacked by the trimethylsilyloxy anion to yield the final homoallylic product **4**.

The proposed mechanism is supported by the results of a mechanistic study by Trehan. There it was shown that the induced selectivity is independent of the stereochemical purity of the mixed acetal when employing a chiral silyl ether com-

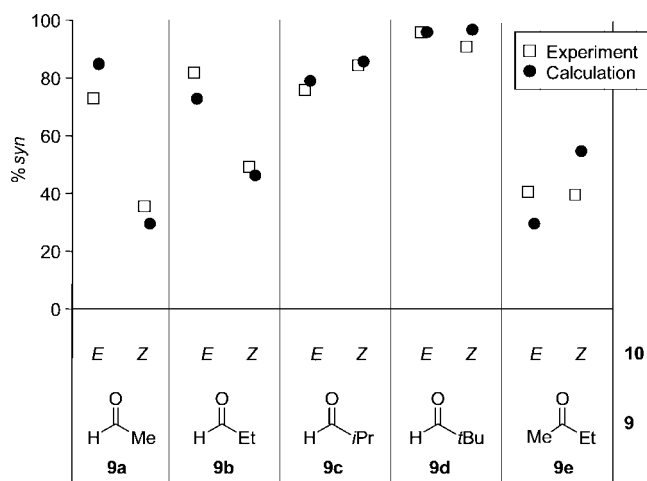

**FIGURE 1.** Experimentally determined and computationally predicted syn/anti selectivities for the crotylation of several aldehydes and butanone with *E*- and *Z*-configured crotyl silane. B3LYP/6-31+G(d)/PCM/UAKS level of theory for all reactions except **9a** + (*E*)-**10** for which BH&HLYP/6-31+G(d)/PCM/UAKS was used.

ound. In consequence of this fact, the authors excluded an alternative S<sub>N</sub>2-type reaction, leaving the shown S<sub>N</sub>1-type reaction as the only reasonable possibility.<sup>4</sup> Several experimental and computational investigations on similar reactions provide a view of the transition state (TS) geometries involved.<sup>5</sup> Recently, we have performed a combined experimental and theoretical study on the diastereoselectivity of MCARs of different carbonyl compounds **9** with *E*- or *Z*-configured crotyl silane (**10**) and trimethylsilyl methyl ether (**11**) (Scheme 3).<sup>6</sup>

In line with previous observations,<sup>7</sup> we found that reaction of both *Z* and *E*-crotyl silane with  $\alpha$ -branched aldehydes like isobutyraldehyde **9c** or pivaldehyde **9d** give the syn product **12c** or **12d**, while butanone **9e** gives the anti product **13e** predominantly. For acetaldehyde **9a** and propionaldehyde **9b**, the anti products **13a** and **13b** are formed with *Z*-crotyl silane and the syn products **12a** and **12b** are obtained with *E*-crotyl silane. The same results were obtained when using acetaldehyde and propionaldehyde dimethyl acetals as substrates. For the elucidation of the origin of diastereoselectivity, we determined the energies for the possible TSs employing density functional theory (DFT) including the effect of the solvent dichloromethane (B3LYP/6-31+G(d)/PCM/UAKS).<sup>8</sup> The experimentally observed stereoselectivities can be rationalized for all substrates by invoking oxocarbenium ion **7**, which is intercepted by the crotyl silane **10** in the stereoselective step (Figure 1). In addition to the strongly required substantiation of the existence of the oxocarbenium ion **7** and the proposed mechanism, we found that in each studied case, three TSs are

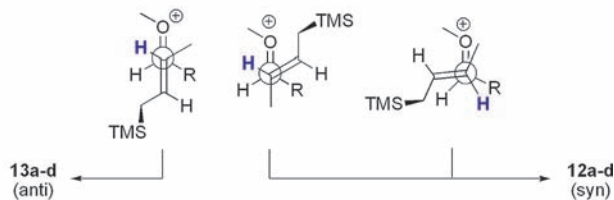
**CHART 1.** Relevant TS Geometries for the Crotylations of Aldehydes and Butanone with *E*-Crotyl Silane as Calculated with B3LYP/6-31+G(d)/PCM/UAKSAldehyde allylations (R = Me, Et, *i*Pr, *t*Bu)

Butanone allylation

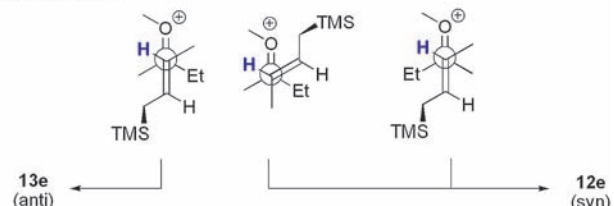

necessary and sufficient to reproduce the experimentally found selectivities (Chart 1).

For both aldehyde and ketone allylations, two TSs where the double bond hydrogen points into the same direction as the methyl group at the oxocarbenium ion are low-energy TSs. Surprisingly, a TS where the substituents of the reaction partners take an eclipsed orientation exists for aldehyde allylations and is lowest in energy for  $\alpha$ -branched aldehydes delivering a straightforward explanation for the high syn selectivity observed. In contrast, no such eclipsed TS conformations exist for the ketone allylations; here, however, a TS with a *Z*-configured oxocarbenium ion must be taken into account.

## Applications of the MCAR in Organic Synthesis

MCARs may be employed for a variety of goals in organic synthesis. Foremost, they can be used to synthesize complex structures with secondary or tertiary ethers,<sup>9</sup> including oxygen-containing heterocycles, which are accessible via an intramolecular variant of the MCAR.<sup>10</sup> Protected homoallylic alcohols can be formed in one step from the corresponding carbonyl compound when silyl ethers such as TMSOBn are used directly.<sup>11</sup>

Extending this approach to the employment of chiral silyl ethers and subsequent ether cleavage establishes an auxiliary-mediated stereoselective formation of homoallylic alcohols. Suitable auxiliaries for the stereoselective allylation of carbonyl compounds are generally derivatives from secondary alcohols bearing one aromatic and one aliphatic side chain such as **14**. Thus, a 1,3-induction ensures a maximum transfer of stereogenic information. The resulting products **16** resemble benzyl-like protected alcohols, which can be deprotected by

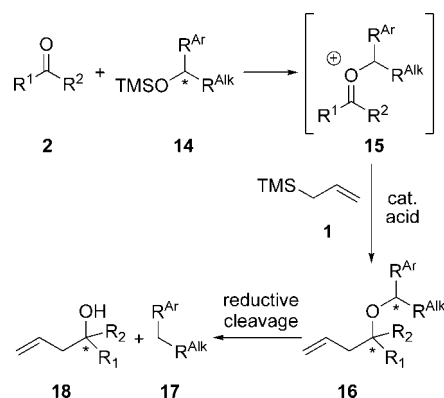
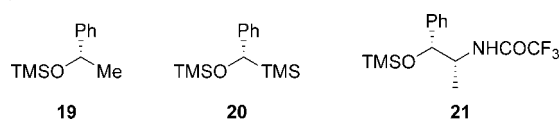
**SCHEME 4.** Auxiliary Mediated Allylation of Carbonyl Compounds and Subsequent Benzyl Ether Cleavage**CHART 2.** Selected Auxiliaries for the Asymmetric Allylation of Aldehydes and Ketones

standard reductive cleavage methods, for example, with sodium in liquid ammonia (Birch conditions) or with lithium in the presence of 4,4'-di-*tert*-butyl-biphenyl to give the homoallylic alcohols **18** or with hydrogen and Pd/C to yield the corresponding saturated alcohols (Scheme 4).

In our group several chiral auxiliaries like **21**<sup>3a</sup> (Chart 2) were developed that allow the stereoselective allylation of both aldehydes and aliphatic methyl ketones in excellent yields and selectivities. Experimental and computational investigations have been carried out to understand the origin of stereoselectivity in these reactions. This Account focuses on the auxiliaries developed by us and others, thereby summarizing the substrate scope characteristics and the mechanistic reasonings for the explanation of stereoselectivity. Furthermore it demonstrates the usefulness of the method in total syntheses of natural products.

It should be noted that there exists a variety of catalytic enantioselective methods for the allylation of carbonyl compounds.<sup>1a</sup> However, while secondary homoallylic alcohols are readily available in high enantiomeric excess from both aliphatic and aromatic aldehydes,<sup>12</sup> the allylation of ketones is mostly limited to aromatic or  $\alpha,\beta$ -unsaturated substrates.<sup>13</sup> In addition, these methods often rely on high catalyst loadings and toxic starting materials such as triallyl tin. The use of the MCAR as an auxiliary-based method for the formation of homoallylic products not only offers a way for the highly selective allylation of aliphatic carbonyl compounds but combines the stereoselective reaction with the introduction of

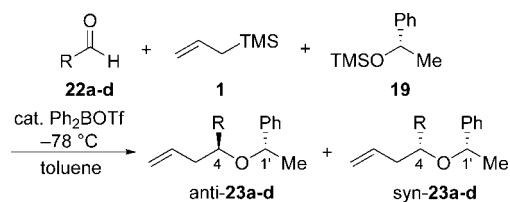
**SCHEME 5.** Allylation of Aldehydes with the Phenyl–Methyl-Substituted Silyl Ether **19****TABLE 1.** Yields and Selectivities for the Allylation of Aldehydes with the Silyl Ether **19**

aldehyde	yield [%]	product <b>23</b> anti/syn
<b>22a</b> , R = (CH <sub>2</sub> ) <sub>8</sub> C=CH <sub>2</sub>	79	92:8
<b>22b</b> , R = <i>i</i> Pr	66	99:1
<b>22c</b> , R = <i>n</i> Hex	74	93:7
<b>22d</b> , R = Ph	77	74:26

a protecting group. Moreover, the chiral inductors are easily available, and nontoxic starting materials are employed.

### MCARs with the Phenyl–Methyl-Substituted Auxiliary

In the first published approach, a simple auxiliary of type **14**, the phenyl–methyl-substituted silyl ether **19**, was employed by Mukaiyama for the allylation of several aldehydes (Scheme 5, Table 1).<sup>3a,14</sup>

The reactions with the phenyl–methyl-substituted auxiliary exhibit two features that are general for aldehyde allylations with aryl–alkyl-substituted auxiliaries published so far: First, the main isomer of the resulting homoallylic ether has an anti configuration with respect to the stereogenic center of the auxiliary at C-1' and the newly formed stereogenic center at C-4. Second, selectivities are typically higher when aliphatic aldehydes are used as substrates instead of aldehydes with unsaturated side chains.

We have also investigated the allylation of butanone with the phenyl-methyl auxiliary **19**, which gave merely a 65:35 mixture of the corresponding tertiary homoallylic ether isomers.<sup>15</sup> While this result can be easily traced back to the more difficult differentiation of a methyl and an ethyl group in contrast to a hydrogen atom and an alkyl chain in aldehyde allylations, we observed the surprising result that the main isomer does not have anti but syn configuration. This feature proved to be typical for other ketone allylations.

For the allylation of butanone, we were able to identify the relevant TSs by a comprehensive computational investigation. The analysis of the conformational degrees of freedom leads to a total of 48 possible TS structures of which 10 contribute significantly (more than 1%) to product formation, making a rational reasoning based on steric interactions or

solvent effects difficult (Chart 3). The calculated ratio of isomers (70:30) is very close to the experimental value of 65:35.

One interesting feature of the calculated TS structures is the position of the phenyl group in relation to the oxocarbenium ion double bond and in relation to the approaching nucleophile. Contrary to expectation, the C–Ph bond is perpendicular to the C=O double bond in all relevant TSs, even when the nucleophile approaches from the face where the phenyl group resides as in the TSs leading to the anti product. This obviously strong stereoelectronic effect results in a lower energy for TSs where the silane approaches from the opposite face to the phenyl group.

### Higher Selectivities Can Be Obtained by Increasing the Size of the Aryl and Alkyl Moieties

When the MCAR of cyclohexylcarbaldehyde (**22c**) with silyl ether **19** and TMSOTf was performed at 0 °C instead of –78 °C, the selectivity dropped to 67:33. A substitution of the auxiliary's phenyl group by a sterically more demanding 2,6-dichlorophenyl moiety allowed the formation of the corresponding homoallylic ether in a selectivity of 91:9 even at 0 °C.<sup>3b</sup>

In the already mentioned mechanistic study by Trehan,<sup>4</sup> the effect of increasing either one or both of the auxiliary substituents on the allylation of hydrocinnamaldehyde **24** was tested, and it was found that an increase of the size of both substituents leads generally to a higher selectivity (Scheme 6, Figure 2). However, this approach seems to be limited because the allylation with the *o*-tolyl–ethyl-substituted silyl ether provides a maximum selectivity of 93:7, while the *o*-tolyl–isopropyl-substituted silyl ether delivered a lower selectivity.

Trehan explains the stereochemical outcome of the MCAR with these silyl ethers by considering the competing TSs **27–30** (Chart 4). In TSs **27** and **28**, the alkyl group stays perpendicular with respect to the C=O double bond, while in TSs **29** and **30**, the aromatic moiety adopts the perpendicular position. The authors argue that by increasing the size of the alkyl moiety,  $R_{\text{Alk}}$ , the TSs **27** and **28** become dominant over **29** and **30** due to hyperconjugation effects. Then, increasing the size of the aromatic moiety,  $R_{\text{Ar}}$ , favors TS **27** over **28**, thus leading to a higher selectivity.

However, this model cannot explain the fact that selectivity drops when going from the *o*-tolyl–ethyl auxiliary to the *o*-tolyl–isopropyl auxiliary. In addition, the explanation is contrary to the stereoelectronic effect found for the allylation of butanone with the phenyl–methyl auxiliary **19**. Thus, the observed selectivity may need to be traced back to the pre-

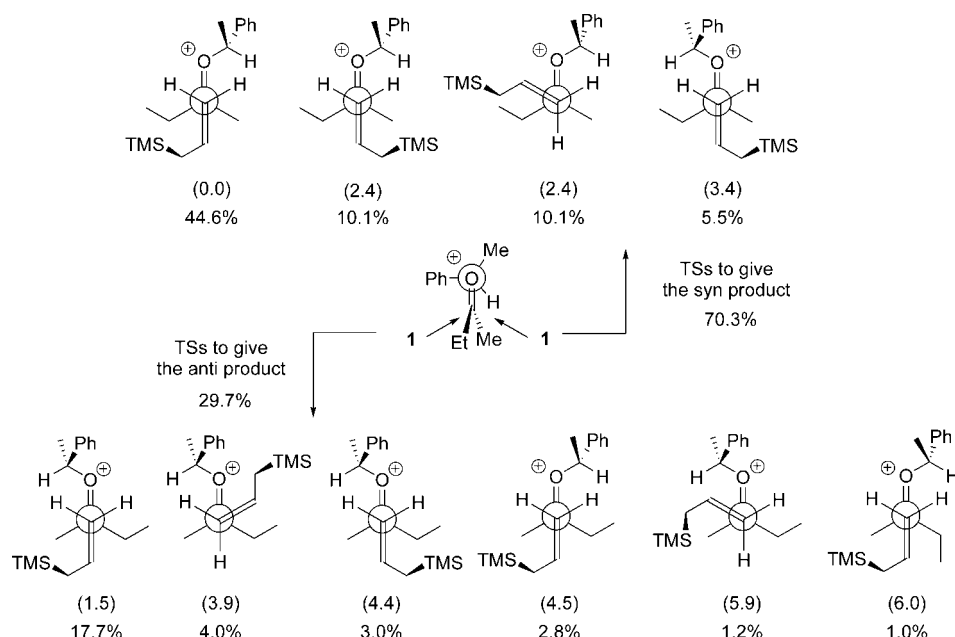
**CHART 3.** Most Relevant TSs for the Formation of the Main syn Isomer and the Minor anti Isomer of the Tertiary Homoallylic Ether from Butanone, Allyltrimethylsilane **1**, and the Phenyl–Methyl Auxiliary **19**<sup>a</sup>

<sup>a</sup> The values in parentheses give the relative energy in  $\text{kJ mol}^{-1}$  as calculated with B3LYP/6-31+G(d)/PCM/UAKS in dichloromethane solution. The relative energy is defined as the difference in energy from the lowest-energy TS. The percentage values correspond to the contribution of the individual TSs to overall product formation according to TS theory.

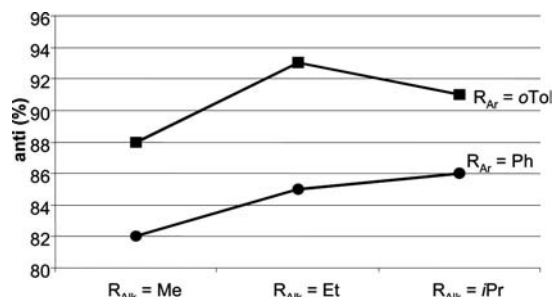
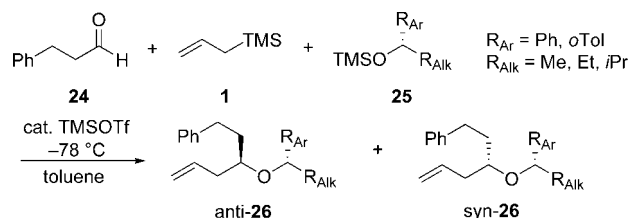
**FIGURE 2.** Selectivities with the aryl–alkyl-substituted silyl ethers **25** for the allylation of **24**.**SCHEME 6.** Allylation of Hydrocinnamaldehyde **24** with Aryl–Alkyl-Substituted Silyl Ethers **25**

ferred attack to the *re*-face of the intermediate oxocarbenium ion **31** with its C–R<sub>Ar</sub> bond perpendicular to the C=O bond as depicted in Chart 5.

## Phenyl–Silyl-Substituted Silyl Ethers for the Asymmetric MCAR of Aldehydes

Based on the silyl ethers developed by Linderman for the auxiliary-mediated Mukaiyama-like aldol reaction,<sup>16</sup> Rychnovsky

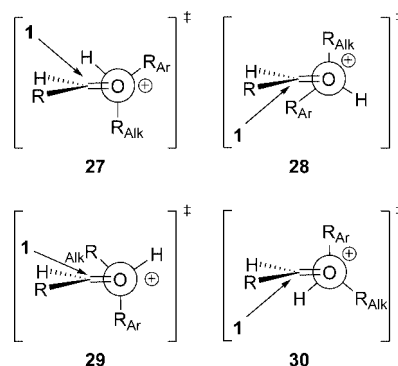
**CHART 4.** Transition States for the Explanation of the Changes in Selectivity in the MCAR of Hydrocinnamaldehyde **24** with Aryl and Alkyl Substituted Silyl Ethers **25**<sup>a</sup>

<sup>a</sup> R = (CH<sub>2</sub>)<sub>2</sub>Ph.

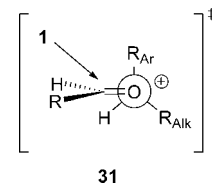
**CHART 5.** Proposed Relevant Attack Trajectory for the MCAR of Hydrocinnamaldehyde **24**<sup>a</sup>

<sup>a</sup> R = (CH<sub>2</sub>)<sub>2</sub>Ph.

prepared a series of phenyl–silyl auxiliaries, **32a–c** (Chart 6), and applied them to the allylation of aliphatic, aromatic, and  $\alpha,\beta$ -unsaturated aldehydes **33** (Scheme 7, Table 2).<sup>17</sup>

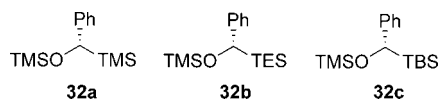
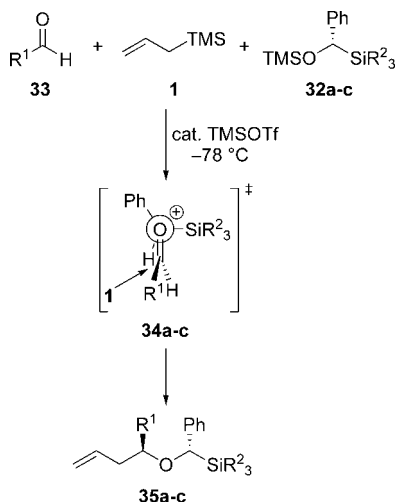
**CHART 6.** Phenyl–Silyl-Substituted Auxiliaries for the MCAR of Aldehydes**SCHEME 7.** Allylation of Aldehydes with Phenyl–Silyl-Substituted Auxiliaries **32a–c****TABLE 2.** Yields and Selectivities for the Allylation of Aldehydes with the Silyl Ethers (SE) **32a–c**

<b>33a</b> , R <sup>1</sup> = C <sub>5</sub> H <sub>11</sub>		<b>33b</b> , R <sup>1</sup> = Ph		<b>33c</b> , R <sup>1</sup> = CH=CHPh	
SE	dr (yield [%])	SE	dr (yield [%])	SE	dr (yield [%])
<b>32a</b>	32:1 (86)	<b>32a</b>	10:1 (96)	<b>32a</b>	6:1 (69)
<b>32b</b>	35:1 (80)	<b>32b</b>	14:1 (98)	<b>32b</b>	8:1 (96)
<b>32c</b>	>20:1 (75)	<b>32c</b>	16:1 (100)	<b>32c</b>	8:1 (76)

Again, the configuration of the main isomer, as well as the level of induction for the three aldehyde types **33a–c**, matches perfectly the findings made before. The size of the silyl group does have some effect on the selectivity of the allylation; however, Rychnovsky identifies the simplest auxiliary of this type, the phenyl–trimethylsilyl auxiliary **32a**, as most practical in organic synthesis. This view is justified in the light of atom economy as well as in the ease of the preparation of the compound, which is accessible by Noyori reduction<sup>18</sup> of the corresponding phenyl–trimethylsilyl ketone in an excellent enantioselectivity of 98% ee. Additionally, the auxiliary is rather practical in total syntheses because the transferred  $\alpha$ -silyl benzyl group can be transformed into a simple benzyl protecting group upon reaction with tetra-*n*-butyl ammonium fluoride (Scheme 8).

Rychnovsky explains the stereochemical outcome of the reaction in terms similar to those of Trehan. Assuming a strong  $\beta$ -silyl effect, the authors propose a perpendicular orientation of the C–Si bond in relation to the oxocarbenium ion double bond in the stereogenic TS **34a–c**. The direction of

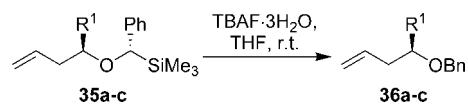
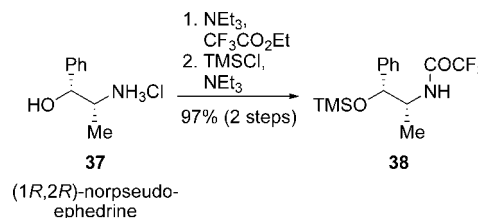
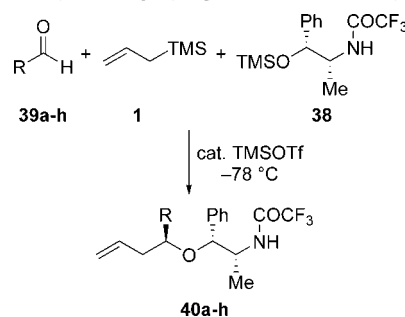
**SCHEME 8.** Cleavage of the  $\alpha$ -Silyl Group of **35a–c****SCHEME 9.** Synthesis of TMS-Protected (1*R*,2*R*)-*N*-Trifluoroacetyl-norpseudoephedrine, **38****SCHEME 10.** Asymmetric MCAR of Aliphatic, Aromatic, and  $\alpha,\beta$ -Unsaturated Aldehydes Employing the NPED Auxiliary **38**

the attack then follows simply: steric hindrance exerted by the phenyl group shifts the attack to the other face, thus leading to the anti isomer of the final product.

## The Norpseudoephedrine Auxiliary for the Synthesis of Secondary Homoallylic Ethers

We have developed a chiral auxiliary based on the natural compound norpseudoephedrine (NPED, **37**) (Scheme 9).<sup>3a</sup> Attaching a trifluoroacetate group to the amino functionality and silylation of the alcohol affords the NPED auxiliary **38** in 97% yield over two steps.<sup>19</sup>

The allylations of various branched, unbranched, and functionalized aliphatic aldehydes **39a–h** exhibit an extraordinarily high stereoselectivity for a wide range of substrates (Scheme 10, Table 3).<sup>19</sup> Following the general trend of the above-mentioned auxiliaries, it is not surprising that aromatic aldehydes are allylated less selectively; however, the allylation of *p*-methoxybenzaldehyde (**39h**) still proceeds in an excellent selectivity of 98:2.

In a detailed experimental study including *in situ* <sup>13</sup>C NMR spectroscopy, isolation and characterization of reaction side products at different reaction temperatures, and reactions with possible intermediates, we were able to propose a reasonable mechanism (Scheme 11) to explain the extraordinarily

**TABLE 3.** Yields and Selectivities for the Allylation of Aldehydes with the NPED Auxiliary **38**

aldehyde	dr (yield [%])
<b>39a</b> , R = Me	>99:1 (52)
<b>39b</b> , R = Et	>99:1 (73)
<b>39c</b> , R = <i>n</i> Hex	>99:1 (81)
<b>39d</b> , R = <i>t</i> Bu	>99:1 (55)
<b>39e</b> , R = CH=CHPh	87:13 (61)
<b>39f</b> , R = <i>c</i> Hex	98:2 (49)
<b>39g</b> , R = Ph	82:18 (73)
<b>39h</b> , R = <i>p</i> -C <sub>6</sub> H <sub>4</sub> OMe	98:2 (80)

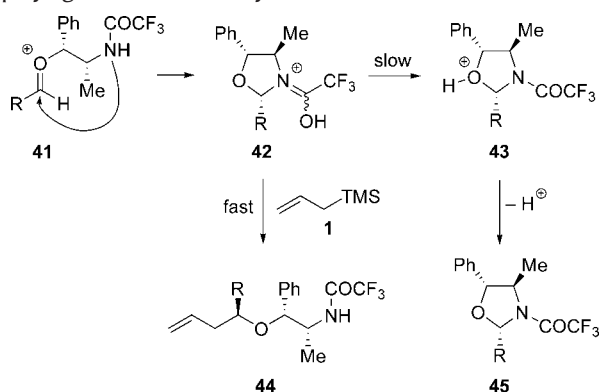
**SCHEME 11.** Mechanism of the Asymmetric MCAR of Aldehydes Employing the NPED Auxiliary **38**

high level of stereoselection.<sup>20</sup> Instead of a direct attack of allyl silane **1** to the oxocarbenium ion **41**, an intramolecular cyclization takes place to give the oxazolidinium ion **42**. In a fast reaction, this ion is attacked by the allyl silane **1** from the upper face, thus leading to almost perfect stereoselection. Alternatively, a slow hydrogen transfer may transform **42** to **43**, which ultimately deprotonates to give the heterocycle **45**. In fact, an increase of the reaction temperature to  $-40\text{ }^{\circ}\text{C}$  results in the formation of **45** as major product. We assume that in the case of aromatic aldehydes (R = Ar), the conjugation decreases the electrophilicity of the oxocarbenium ion carbon atom to make it less susceptible to intramolecular cyclization. Thus, **42** is not formed, and the reaction proceeds via attack to the open-chain ion **41**, leading to an overall somewhat reduced selectivity.

In line with the mechanistic proposal, the method is totally reagent-controlled when  $\beta$ -chiral aldehydes are employed as substrates.<sup>19</sup> The difference in diastereomeric excess (de) between matched and mismatched pairs for the studied molecules is typically less than 10%.

## A Reversed but Still Excellent Selectivity Is Found for the MCAR of Ketones with the NPED Auxiliary

We have also applied the NPED auxiliary to the allylation of ketones and found high levels of stereoselection when ali-

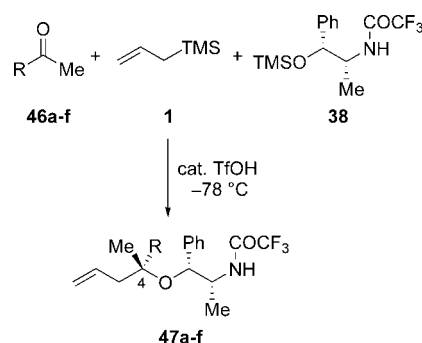
**SCHEME 12.** Asymmetric MCAR of Ketones Employing the NPED Auxiliary **38****TABLE 4.** Yields and Selectivities for the Allylation of Ketones with the NPED Auxiliary **38**

ketone	dr (yield [%])
<b>46a</b> , R = Et	90:10 (87)
<b>46b</b> , R = <i>n</i> Pent	88:12 (79)
<b>46c</b> , R = <i>i</i> Pr	>96:4 (58)
<b>46d</b> , R = <i>t</i> Bu	91:9 (22)
<b>46e</b> , R = (CH <sub>2</sub> ) <sub>2</sub> OAllyl	91:9 (73)
<b>46f</b> , R = (CH <sub>2</sub> ) <sub>2</sub> OTBDPS	98:2 (98)

phatic methyl ketones **46a–f** were employed as substrates (Scheme 12, Table 4).<sup>21</sup> Thus, even the allylation of the most difficult substrate butanone (**46a**) was achieved in a selectivity of 90:10 at  $-78\text{ }^{\circ}\text{C}$ . In line with the result of the allylation of butanone with the phenyl–methyl auxiliary, the main isomer does not have anti configuration as in the allylation of aldehydes but syn configuration. Again, a strong reagent control is found for the allylation of chiral ketones with no more than 5% difference in the diastereomeric excess for the matched and mismatched pair combinations.<sup>22</sup>

Except for the reversed induction, three other points must be mentioned when comparing the MCAR of ketones and aldehydes: First, TMSOTf is not sufficient to initiate the reaction with ketones; instead, TfOH must be employed. Since TfOH rapidly reacts with allyl silane to form TMSOTf, we assume that an equilibrium exists so that the concentration of TfOH is sufficient to catalyze the reaction. This view is substantiated by the observation that there is no conversion when the reaction is performed at temperatures significantly above the boiling point of propene ( $-47\text{ }^{\circ}\text{C}$ ). Second, while the reaction of aldehydes is finished within several minutes, the reaction time for ketone allylations requires up to 2 h to achieve 95% yield. Third, aromatic or  $\alpha,\beta$ -unsaturated ketones show almost no conversion. While this poses a limitation to the scope of the reaction, it may provide the opportunity to perform allylations chemoselectively when an aliphatic and an aromatic ketone are present in the substrate.

The cleavage of the auxiliary side chain from the homoallylic ether is possible by employing standard or modified Birch conditions (sodium in liquid ammonia or lithium with di-*tert*-butyl-biphenyl in THF, respectively). No cleavage takes place with hydrogen on Pd/C, thus providing a possibility to differentiate between the transferred NPED moiety and simple benzyl protecting groups at other positions in the molecule.

### The Origin of Stereoselectivity for the Allylation of Butanone with the NPED Auxiliary: A Computational Study

The lack of a heterocyclic byproduct and the reversed stereoselectivity makes an identical mechanism as found for the allylation of aldehydes unlikely. We therefore assumed that the selectivity should be traced back to the direct attack of allyltrimethylsilane to the intermediately formed oxocarbenium ion.

In order to substantiate this proposal and to gain insight into the structures of relevant TSs, we performed a computational study on the stereogenic step.<sup>23</sup> We chose a systematic approach, first defining all possible TS structures by identification of the conformational degrees of freedom and then determining their relative energies by geometry optimization and frequency calculation in dichloromethane solution using the B3LYP/6-31+G(d)/PCM/UAKS level of theory. However, the large number of possible TSs (almost 300) in combination with the size of the system (61 atoms, 28 non-hydrogen atoms) made this approach not feasible. We therefore developed a screening process that allowed us to select potentially relevant TSs via B3LYP//AM1 calculation before performing time-consuming full optimizations and frequency calculations. From the selected subset of about 60 TSs, we found that 14 TSs needed to be taken into account to correctly reproduce the experimental value (calculated 85:15; experimental 90:10). In these TSs, the oxocarbenium ion **48** is always *E*-configured and adopts one of the three conformations shown in Figure 3.

An attack on both faces of **48** takes place, however with different rates, leading to the observed isomer ratio. The main attack trajectory, accounting for 75% of product formation, is the attack on the *Si*-face of conformation **48**<sub>1</sub>. For **48**<sub>1</sub>, attack on the face opposite to the phenyl group is strongly preferred over attack on the other face; on the other hand, this is not the case for conformation **48**<sub>2</sub>. TSs in which **48** adopts conformations **48**<sub>2</sub> or **48**<sub>3</sub> are only relevant in solution because the added steric interactions within the TS are counterbalanced by an extraordinary stabilization by the solvent dichloromethane.

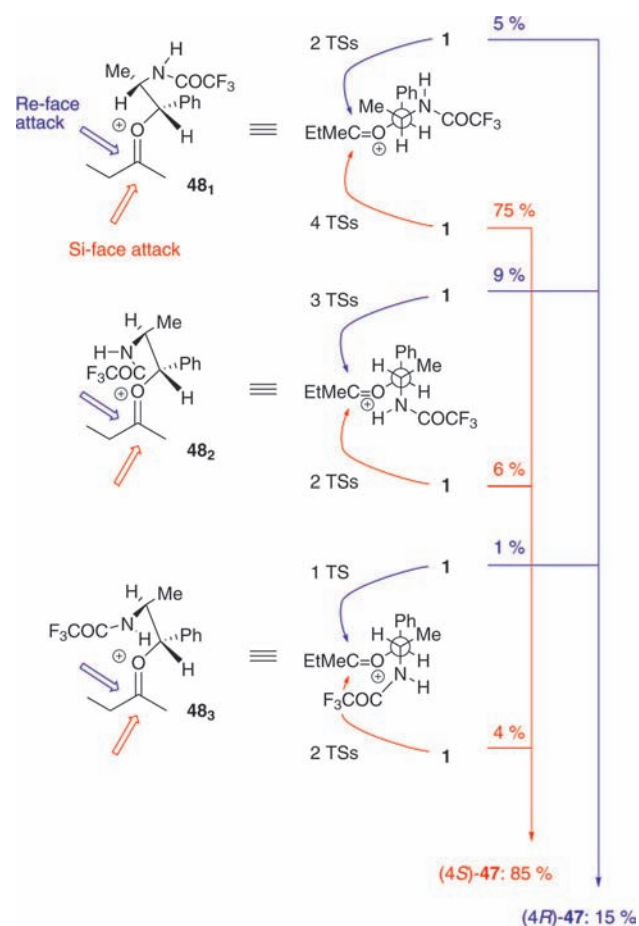

**FIGURE 3.** Main attack trajectories for the formation of the tertiary homoallylic ether **47a**. The contribution to product formation is the sum of the individual TS contributions as calculated by B3LYP/6-31+G(d)/PCM/UAKS according to transition state theory. The individual TSs for the same attack trajectory differ in the relative orientation of the double bonds of **48** and **1**.

### Ketone Allylations with Analogues of the NPED Auxiliary

Having found one suitable auxiliary for ketone allylations, we varied the substituents of the auxiliary to examine their effect on the selectivity (Scheme 13).<sup>24</sup> We observed that an electron-withdrawing group at the amino terminus is necessary to obtain the homoallylic product; a simple acetate protecting group led to no conversion at all (Scheme 14, Table 5). On the other hand, the trifluoroacetamide group may be replaced by a trichloroacetamide or a trifluoromethylsulfonyl group; however, almost no effect on the selectivity was observed.

A replacement of the phenyl group at the C-1 position by a 2,6-dichlorophenyl group in **55** or a naphthyl group in **56** resulted in somewhat higher selectivities of 92:8 and 93:7, respectively. We also replaced the phenyl group by simple alkyl groups (Et, *i*Pr, *t*Bu), but in no case the selectivity exceeded the ratio of 90:10 as found for the NPED auxiliary.

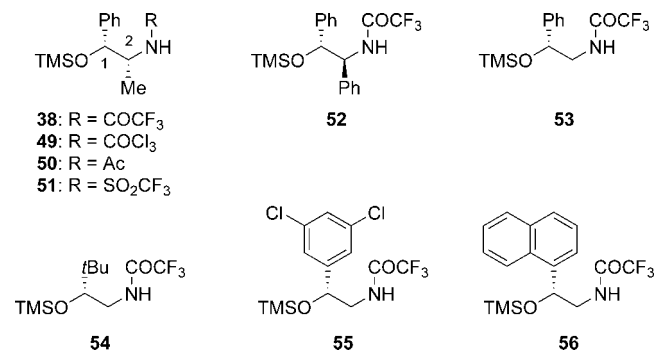
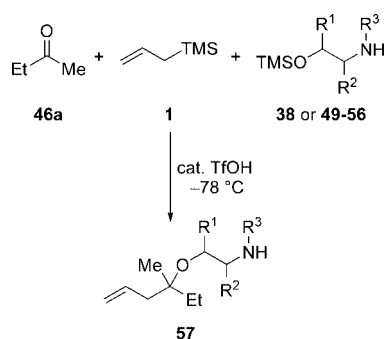

**SCHEME 13.** Analogues of the NPED Auxiliary **38****SCHEME 14.** Allylation of Butanone (**46a**) with Analogues of the NPED Auxiliary **38****TABLE 5.** Yields and Selectivities for the Allylation of Butanone **46a** with Analogues of the NPED Auxiliary **38**

auxiliary	dr (yield [%])
<b>38</b>	90:10 (80)
<b>49</b>	90:10 (71)
<b>50</b>	<sup>a</sup>
<b>51</b>	87:13 (30)
<b>52</b>	95:5 (95)
<b>53</b>	89:11 (90)
<b>54</b>	67:33 (15)
<b>55</b>	92:8 (40)
<b>56</b>	93:7 (50)

<sup>a</sup> No conversion.

In addition, these auxiliaries have no practical use since the formed homoallylic ether cannot be cleaved easily.

One important result was that a removal of the methyl group at C-2 had only a small effect on the selectivity, which decreased to 89:11. The auxiliary **53** is easily accessible starting from mandelic acid which, in contrast to the NPED auxiliary precursor, is commercially available in both enantiomeric forms.<sup>25</sup> Replacing the methyl group at C-2 by other substituents leads to an increased selectivity: the best result was obtained with the diphenyl-NPED auxiliary **52** leading to the corresponding homoallylic ether of butanone in an isomer ratio of 95:5 at  $-78$  °C. It should be mentioned that a reduction of the reaction temperature allows a further increase of

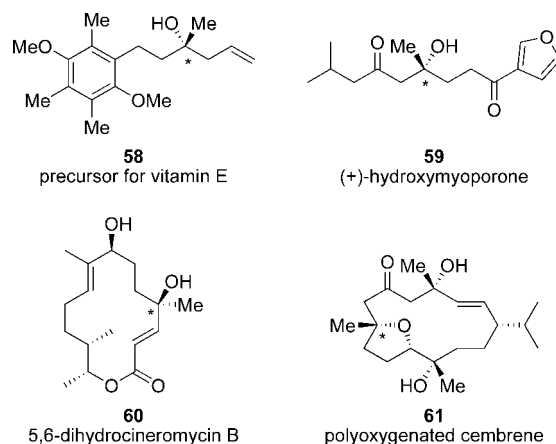
**SCHEME 15.** The Asymmetric MCAR of Aliphatic Ketones As Key Step for the Total Synthesis of Natural Product Compounds<sup>a</sup><sup>a</sup> The \* marks the stereogenic center established by the asymmetric MCAR.

selectivity. Moreover, a purification is possible by crystallization, since the two stereoisomers formed are diastereomers.

## NPED and Derivatives Have Been Used in Total Synthesis of Natural Products

Natural products with stereogenic centers bearing a tertiary methyl carbinol can easily be synthesized employing the aforementioned procedure. Thus, we were able to prepare compounds as divergent as precursors for vitamin E<sup>26</sup> (**58**), (+)-hydroxymyoporone<sup>27</sup> (**59**), 5,6-dihydrocineromycin B<sup>28</sup> (**60**), and the polyoxygenated cembrene<sup>29</sup> (**61**) by using the NPED auxiliary **38** or its derivative **53** (Scheme 15).

In the course of the syntheses, the auxiliary side chain was cleaved by subjecting the allylation product to Birch conditions (sodium and liquid ammonia) or modified Birch conditions<sup>25</sup> using lithium and di-*tert*-butyl-biphenyl in tetrahydrofuran.

In the following, the synthesis of cembrene **61** is outlined. Retrosynthetically, the compound may be broken down into the two almost equally sized building blocks, **63** and **64**, that can be coupled by a nucleophilic epoxide opening reaction (Scheme 16).

Scheme 17 displays the synthesis of the building block **63**. In the first step, the asymmetric MCAR with the mandelic acid derivative *ent*-**53** is used to transform the ketone **65** into the homoallylic ether **66** in an excellent diastereomeric ratio of 95:5. In the following step, the auxiliary side chain is cleaved under modified Birch conditions, and the resulting alcohol is then protected as a PMB ether. Sharpless dihydroxylation at the homoallylic double bond affords compound **67**, which is finally transformed into the epoxide **63** that could then be coupled with the building block **64**.

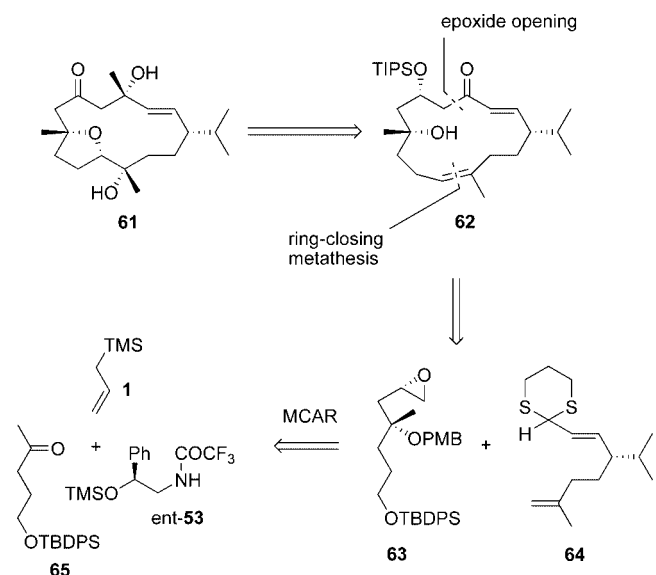
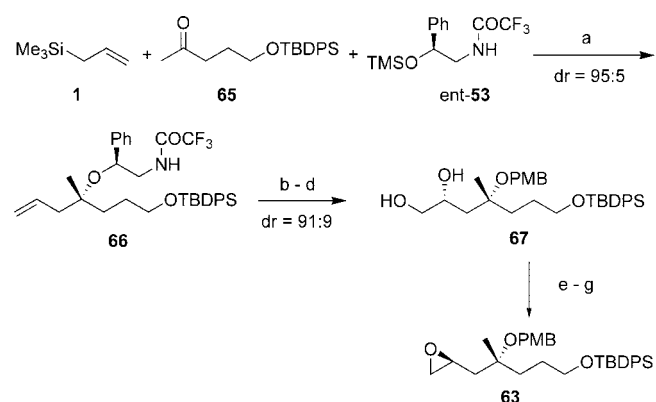
SCHEME 16. Retrosynthetic Analysis for the Total Synthesis of **61**SCHEME 17<sup>a</sup>

<sup>a</sup> (a) 20 mol % TfOH, CH<sub>2</sub>Cl<sub>2</sub>, -196 → -90 °C; (b) Li, DBBP, THF, -78 → -45 °C, 71% over two steps; (c) PMBOC(=NH)CCl<sub>3</sub>, 7 mol % La(OTf)<sub>3</sub>, toluene, r.t., 77%; (d) 1 mol % K<sub>2</sub>OsO<sub>2</sub>(OH)<sub>4</sub>, 5 mol % (DHQD)<sub>2</sub>Pyr, K<sub>3</sub>[Fe(CN)<sub>6</sub>], K<sub>2</sub>CO<sub>3</sub>, <sup>1</sup>BuOH/H<sub>2</sub>O = 1:1, 0 °C; (e) PivCl, pyridine, CH<sub>2</sub>Cl<sub>2</sub>, 0 °C → r.t., 64% over two steps; (f) MsCl, NEt<sub>3</sub>, cat. DMAP, CH<sub>2</sub>Cl<sub>2</sub>, r.t., 83%; (g) K<sub>2</sub>CO<sub>3</sub>, MeOH, r.t., quant. DBBP = 4,4'-di-*tert*-butyl-biphenyl; (DHQD)<sub>2</sub>Pyr = hydroquinidine-(2,5-diphenyl-4,6-pyrimidinediyl)diether; DMAP = 4-(dimethylamino)pyridine; Ms = methanesulfonyl; Piv = pivalyl; PMB = 4-methoxybenzyl; THF = tetrahydrofuran; Tf = trifluoromethanesulfonyl.

## Synthesis of Homoallylic Ethers with Two Newly Formed Stereogenic Centers

The employment of  $\gamma$ -substituted allyl silanes instead of allyl trimethylsilane in the MCAR of butanone (**46a**) affords tertiary homoallylic ethers with two newly formed stereogenic centers. We have prepared substituted allyl silanes **68** with R = Me, Et, *n*Pr, and Ph in both *E*- and *Z*-configurations and employed them in the MCAR of butanone (**46a**) with the NPED auxiliary *ent*-**38** (Scheme 18, Table 6).<sup>30</sup> While the reactions with branched aliphatic (R = *i*Pr) and aromatic  $\gamma$ -substituents (R = Ar) did not afford the desired product, we obtained good yields and high selectivities using the allyl silanes with

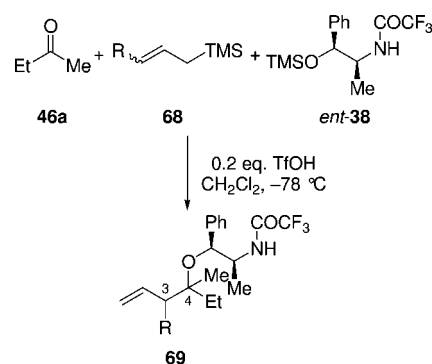
SCHEME 18. Crotylation of Butanone (**46a**) with the NPED Auxiliary *ent*-**38**TABLE 6. Selectivities for the Crotylation of Butanone (**46a**) with the NPED Auxiliary *ent*-**38**

silane	product	stereochemistry of main isomer	dr
<b>68a</b> , R = H	<b>69a</b> , R = H	4 <i>R</i>	90:10
<b>68b</b> , <i>E</i> , R = Me	<b>69b</b> , R = Me	3 <i>S</i> ,4 <i>R</i>	90:10
<b>68c</b> , <i>Z</i> , R = Me	<b>69c</b> , R = Me	3 <i>S</i> ,4 <i>R</i>	75:25
<b>68d</b> , <i>E</i> , R = Et	<b>69d</b> , R = Et	3 <i>R</i> ,4 <i>S</i>	70:30
<b>68e</b> , <i>Z</i> , R = Et	<b>69e</b> , R = Et	3 <i>R</i> ,4 <i>S</i>	86:14
<b>68f</b> , <i>E</i> , R = <i>n</i> Pr	<b>69f</b> , R = <i>n</i> Pr	3 <i>R</i> ,4 <i>S</i>	82:18
<b>68g</b> , <i>Z</i> , R = <i>n</i> Pr	<b>69g</b> , R = <i>n</i> Pr	3 <i>R</i> ,4 <i>S</i>	93:7
<b>68h</b> , <i>E</i> , R = <i>n</i> Bu	<b>69h</b> , R = <i>n</i> Bu	3 <i>R</i> ,4 <i>S</i>	85:15
<b>68i</b> , <i>Z</i> , R = <i>n</i> Bu	<b>69i</b> , R = <i>n</i> Bu	3 <i>R</i> ,4 <i>S</i>	95:5

unbranched alkyl substituents (R = Me, Et, *n*Pr), but only at a prolonged reaction time of several days.

All products have a 3,4-anti relationship of the newly generated stereogenic centers with a simple dr > 100:1, whereas the induced diastereoselectivity ranges from 70:30 to 95:5 depending on the double bond configuration and the length of the alkyl substituent. Thus, the highly preferred formation of the 3,4-anti product is nearly not influenced by the double bond geometry of the employed allyl silanes. This is in line with the observations made for the simple MCAR of butanone (**46a**) with crotyl silane **10** and TMSOME (**11**) as silyl ether.<sup>6</sup> Rather surprising however, is the result that the induced diastereoselectivity is inverted when going from crotyl silanes **68a,b** to pentenyl silanes **68d,e** and longer-chained allyl silanes **68f-i**.

## Summary and Outlook

Our auxiliary-mediated allylation of aldehydes and ketones with allyl silanes in the presence of chiral benzyl silyl ethers based on norpseudoephedrine and analogues to give secondary and tertiary homoallylic alcohols is a powerful method in asymmetric C–C bond formation. Especially in the case of aliphatic substrates, the obtained selectivities often outperform alternative catalytic methods. The ethers can easily be transformed into the corresponding alcohols by reductive methods. In the case of aliphatic aldehydes and ketones, the MCAR

with the NPED auxiliary gives induced diastereoselectivities of up to 99:1 and 98:2, respectively. The auxiliary can be used as protecting group, which is advantageous in total synthesis making this procedure highly effective, since the C–C bond formation and the introduction of the auxiliary as protecting group takes place in one process. The mechanism and origin of stereoselectivity for this reaction was elucidated by both experimental and computational means. However, since the protecting group quality of the NPED auxiliary is limited, we are now developing novel auxiliaries, which give similar selectivities and are more suitable as protecting groups. In addition, a computational study addressing the unusual reversal of selectivity when going from butanone crotylation to pentenylation with the NPED auxiliary is in progress.

*We thank the DFG and the Fonds der Chemischen Industrie for generous support. T.K. thanks the Studienstiftung des deutschen Volkes for a Ph.D. scholarship.*

#### BIOGRAPHICAL INFORMATION

**Lutz F. Tietze**, born in 1942 in Berlin, Germany, studied chemistry at the Universities of Kiel and Freiburg and obtained his Ph.D. in 1968 under the supervision of B. Franck. It was followed by postdoctoral studies at the Massachusetts Institute of Technology, Cambridge, Massachusetts, with George Büchi and at the University of Cambridge, Great Britain, with Alan R. Battersby. After his habilitation in Münster in 1975, he was promoted to professor at the University of Dortmund, and in 1978, he became professor and director of the institute of organic chemistry at the University of Göttingen. He has published over 400 papers, owns 31 patents, and has written three books one of which has been translated into five languages. Among his many awards he recently received the prestigious Emil Fischer Goldmedal of the German Chemical Society, the Grignard-Wittig Award of the Société Française de Chimie, and the Prix Charles Mentzer of the Société de Chimie Thérapeutique.

**Tom Kinzel**, born in 1977 in Erfurt, Germany, started studying chemistry at the University of Göttingen, Germany, in October 1998. After staying in the People's Republic of China in 2001/2002 studying Chinese at the University of Nanjing and joining the working group of Wolfgang Hennig at the Chinese Academy of Sciences in Shanghai, he returned to Göttingen to receive his diploma in Chemistry in July 2004 and his Ph.D. in January 2008 under the guidance of Lutz F. Tietze. He is now a postdoctoral researcher in the research group of Stephen L. Buchwald at the Massachusetts Institute of Technology, Cambridge, Massachusetts.

**C. Christian Brazel** was born in Giessen, Germany, in 1980. He started studying chemistry at the University of Marburg, Germany, in October 1999. After staying at the University of Dortmund, Germany, in 2002, he went to the University of Göttingen, Germany, and received his diploma degree in chemistry in July 2004 and his Ph.D. in April 2008 under the guidance of Lutz F. Tietze. His

thesis research comprises the synthesis of diterpene natural products. He is now a postdoctoral researcher in the research group of Max Malacria at the University Pierre et Marie Curie, Paris, France.

#### FOOTNOTES

\*To whom correspondence should be addressed. Telephone +49551393271; fax +49551399476; e-mail ltietze@gwdg.de.

#### REFERENCES

- For general reviews on allylations see: (a) Denmark, S. E.; Fu, J. Catalytic Enantioselective Addition of Allylic Organometallic Reagents to Aldehydes and Ketones. *Chem. Rev.* **2003**, *103*, 2763–2793. (b) Masse, C. E.; Panek, J. S. Diastereoselective Reactions of Chiral Allyl- and Allenylsilanes with Activated C=X.  $\pi$  Bonds. *Chem. Rev.* **1995**, *95*, 1293–1316. (c) Yamamoto, Y.; Asao, N. Selective Reactions Using Allylic Metals. *Chem. Rev.* **1993**, *93*, 2207–2293.
- For domino reactions, see: (a) Tietze, L. F.; Brasche, G.; Gericke, K. M. *Domino Reactions in Organic Synthesis*; Wiley-VCH: Weinheim, Germany, 2006. (b) Ramón, D. J.; Yus, M. Asymmetric Multicomponent Reactions (AMCRSs): The New Frontier. *Angew. Chem., Int. Ed.* **2005**, *44*, 1602–1634. (c) Tietze, L. F. Domino Reactions in Organic Synthesis. *Chem. Rev.* **1996**, *96*, 115–136. (d) Tietze, L. F.; Beifuss, U. Sequential Transformations in Organic Chemistry: A Synthetic Strategy with a Future. *Angew. Chem., Int. Ed.* **1993**, *32*, 131–163.
- (a) Tietze, L. F.; Dölle, A.; Schiemann, K. Diastereoselective Addition of Allylsilanes to Aldehydes: Synthesis of Enantiomerically Pure Homoallylic Alcohols. *Angew. Chem., Int. Ed. Engl.* **1992**, *31*, 1372–1373. (b) Mekhaifia, A.; Markó, I. E. The Silyl Modified Sakurai (SMS) Reaction. An Efficient and Versatile One-Pot Synthesis of Homoallylic Ethers. *Tetrahedron Lett.* **1991**, *32*, 4779–4782. (c) Mukaiyama, T.; Ohshima, M.; Miyoshi, N. An Efficient and Convenient Method for the Asymmetric Allylation of Aldehydes with Allyltrimethylsilane Catalyzed by Diphenylboryl Triflate. *Chem. Lett.* **1987**, 1121–1124.
- Manju, K.; Trehan, S. Origin of diastereoselectivity in the addition of allylsilane to chiral acyclic mixed acetals. *Chem. Commun.* **1999**, 1929–1930.
- (a) Mayer, P. S.; Morton, T. H. Gas-Phase Electrophilic Attack of a Double Bond Exhibits Stereoselectivity. *J. Am. Chem. Soc.* **2002**, *124*, 12928–12929. (b) Bottoni, A.; Costa, A. L.; Di Tommaso, D.; Rossi, I.; Tagliavini, E. New Computational and Experimental Evidence for the Mechanism of the Sakurai Reaction. *J. Am. Chem. Soc.* **1997**, *119*, 12131–12135. (c) Denmark, S. E.; Hosoi, H. Stereochemical Studies on the Addition of Allylstannanes to Aldehydes. The SE' Component. *J. Org. Chem.* **1994**, *59*, 5133–5135. (d) Denmark, S. E.; Almstead, N. G. Stereochemical Studies on the Addition of Allylsilanes to Aldehydes. The SE' Component. *J. Org. Chem.* **1994**, *59*, 5130–5132. (e) Denmark, S. E.; Willson, T. M. Mechanistic and Stereochemical Divergence in the Allylsilane-Acetal Addition Reaction. *J. Am. Chem. Soc.* **1989**, *111*, 3475–3476. (f) Denmark, S. E.; Weber, E. J. Stereochemistry of Allylmetal-Aldehyde Condensations. 2. Allylstannanes. *J. Am. Chem. Soc.* **1984**, *106*, 7970–7971. (g) Broeker, J. L.; Hoffmann, R. W.; Houk, K. N. Conformational Analysis of Chiral Alkenes and Oxonium Ions: Ab Initio Molecular Orbital Calculations and an Improved MM2 Force Field. *J. Am. Chem. Soc.* **1991**, *113*, 5006–5017. (h) Paddon-Row, M. N.; Rondan, N. G.; Houk, K. N. Staggered Models for Asymmetric Induction: Attack Trajectories and Conformations of Allylic Bonds from ab Initio Transition Structures of Addition Reactions. *J. Am. Chem. Soc.* **1982**, *104*, 7162–7166.
- Tietze, L. F.; Kinzel, T.; Schmatz, S. Origin of Syn/Anti Diastereoselectivity in Aldehyde and Ketone Crotylation Reactions: A Combined Theoretical and Experimental Study. *J. Am. Chem. Soc.* **2006**, *128*, 11483–11495.
- Denmark, S. E.; Weber, E. J. On the Stereochemistry of Allylmetal-Aldehyde Condensations. *Helv. Chim. Acta* **1983**, *159*, 1655–1660.
- (a) Cossi, M.; Scalmani, G.; Rega, N.; Barone, V. New Developments in the Polarizable Continuum Model for Quantum Mechanical and Classical Calculations on Molecules in Solution. *J. Chem. Phys.* **2002**, *117*, 43–54. (b) Mennucci, B.; Cammi, R.; Tomasi, J. Analytical Free Energy Second Derivatives with Respect to Nuclear Coordinates: Complete Formulation for Electrostatic Continuum Solvation Models. *J. Chem. Phys.* **1999**, *110*, 6858–6870. (c) Becke, A. D. Density-Functional Thermochemistry. III. The Role of Exact Exchange. *J. Chem. Phys.* **1993**, *98*, 5648–5652. (d) Lee, C.; Yang, W.; Parr, R. G. Development of the Colle-Salvetti Correlation-Energy Formula into a Functional of the Electron Density. *Phys. Rev. B* **1988**, *37*, 785–789. (e) Becke, A. D. Density-Functional Exchange Energy Approximation with Correct Asymptotic Behavior. *Phys. Rev. A* **1988**, *38*, 3098–3100.
- (a) Pospíšil, J.; Markó, I. E. Total Synthesis of Jerangolid D. *J. Am. Chem. Soc.* **2007**, *129*, 3516–3517. (b) Carter, K. D.; Panek, J. S. Total Synthesis of Herbimycin A. *Org. Lett.* **2004**, *6*, 55–57. (c) Tietze, L. F.; Völkel, L. Total Synthesis of the Macrolide Antibiotic 5,6-Dihydroxycineromycin B. *Angew. Chem., Int. Ed.*

- 2001, 40, 901–902. (d) Tietze, L. F.; Wegner, C.; Wulff, C. First Total Synthesis and Determination of the Absolute Configuration of the Stress Factor (+)-Hydroxymyoporone. *Chem.—Eur. J.* **1999**, 5, 2885–2889.
- 10 (a) Su, Q.; Panek, J. S. [4 + 2]-Annulations of Chiral Organosilanes: Application to the Total Synthesis of Leucascandrolide A. *J. Org. Chem.* **2007**, 72, 2–24. (b) Pospíšil, J.; Kumamoto, T.; Markó, I. E. Highly Diastereoselective Silyl-Modified Sakurai Multicomponent Reaction. *Angew. Chem., Int. Ed.* **2006**, 45, 3357–3360. (c) Su, Q.; Panek, J. S. Total Synthesis of (+)-Leucascandrolide A. *Angew. Chem., Int. Ed.* **2005**, 44, 1223–1225. (d) Huang, H.; Panek, J. S. Stereoselective Synthesis of Functionalized Dihydropyrans via a Formal [4 + 2]-Annulation of Chiral Crotylsilanes. *J. Am. Chem. Soc.* **2004**, 126, 2425–2430.
- 11 See, for example: Liu, P.; Binnun, E. D.; Schaus, J. V.; Valentino, N. M.; Panek, J. S. Stereoselective Additions of Chiral (*E*)-Crotylsilanes to Thionium Ions: Asymmetric Synthesis of Homoallylic Thioethers. *J. Org. Chem.* **2002**, 67, 1705–1707.
- 12 (a) Sharma, R. K.; Samuelson, A. G. Asymmetric Allylation of Aldehydes with Chiral Platinum Phosphinite Complexes. *Tetrahedron: Asymmetry* **2007**, 18, 2387–2393. (b) Traverse, J. F.; Zhao, Y.; Hoveyda, A. H.; Snapper, M. L. Proline-Based *N*-Oxides as Readily Available and Modular Chiral Catalysts. Enantioselective Reactions of Allyltrichlorosilane with Aldehydes. *Org. Lett.* **2005**, 7, 3151–3154. (c) Chelucci, G.; Murineddu, G.; Pinna, G. A. Chiral Pyridine *N*-Oxides: Useful Ligands for Asymmetric Catalysis. *Tetrahedron: Asymmetry* **2004**, 15, 1373–1389. (d) Kina, A.; Shimada, T.; Hayashi, T. A New Approach to Axially Chiral Bipyridine *N,N*-Dioxides Bearing Aromatic Substituents and their Use for Catalytic Asymmetric Allylation of Aldehydes with Allyl(trichloro)silane. *Adv. Synth. Catal.* **2004**, 346, 1169–1174.
- 13 (a) Kanai, M.; Wada, R.; Shibuguchi, T.; Shibasaki, M. Cu(I)-catalyzed asymmetric allylation of ketones and ketimines. *Pure Appl. Chem.* **2008**, 80, 1055–1062. (b) Wooten, A. J.; Kim, J. G.; Walsh, P. J. Highly Concentrated Catalytic Asymmetric Allylation of Ketones. *Org. Lett.* **2007**, 9, 381–384. (c) Wadamoto, M.; Yamamoto, H. Silver-Catalyzed Asymmetric Sakurai-Hosomi Allylation of Ketones. *J. Am. Chem. Soc.* **2005**, 127, 14556–14557. (d) Lu, J.; Hong, M.-L.; Ji, S.-J.; Teo, Y.-C.; Loh, T.-P. Enantioselective Allylation of Ketones Catalyzed by Chiral In(III)-PYBOX Complexes. *Chem. Commun.* **2005**, 4217–4218. (e) Teo, Y.-C.; Goh, J.-D.; Loh, T.-P. Catalytic Enantioselective Allylation of Ketones via a Chiral Indium(III) Complex. *Org. Lett.* **2005**, 7, 2743–2745. (f) Kim, J. G.; Waltz, K. M.; Garcia, I. F.; Kwiatkowski, D.; Walsh, P. J. Catalytic Asymmetric Allylation of Ketones and a Tandem Asymmetric Allylation/Diastereoselective Epoxidation of Cyclic Enones. *J. Am. Chem. Soc.* **2004**, 126, 12580–12585.
- 14 (a) Mukaiyama, T.; Nagaoka, H.; Murakami, M.; Ohshima, M. A Facile Synthesis of Homoallyl Ethers. The Reaction of Acetals with Allyltrimethylsilanes Promoted by Trityl Perchlorate or Diphenylboryl Triflate. *Chem. Lett.* **1985**, 977–980. (b) Kato, J.; Iwasawa, N.; Mukaiyama, T. A Novel Method for the Preparation of Symmetrical and Unsymmetrical Ethers. Trityl Perchlorate Promoted Reduction of Carbonyl Compounds with Triethylsilane. *Chem. Lett.* **1985**, 743–746.
- 15 Previously unpublished results.
- 16 (a) Linderman, R. J.; Chen, K. Highly Diastereoselective Intramolecular Allylation Reactions of Mixed Silyl-Substituted Acetals. *J. Org. Chem.* **1996**, 61, 2441–2453. (b) Linderman, R. J.; Chen, S. Diastereoselective addition of alkynylstannanes to alpha stannyl substituted mixed acetals: Synthesis of precursors for allenyl carbinols. *Tetrahedron Lett.* **1996**, 37, 3819–3822.
- 17 Huckins, J. R.; Rychnovsky, S. D. Synthesis of Optically Pure Arylsilylcarbinols and Their Use as Chiral Auxiliaries in Oxocarbenium Ion Reactions. *J. Org. Chem.* **2003**, 68, 10135–10145.
- 18 Noyori, R.; Hashiguchi, S. Asymmetric Transfer Hydrogenation Catalyzed by Chiral Ruthenium Complexes. *Acc. Chem. Res.* **1997**, 30, 97–102.
- 19 Tietze, L. F.; Schiemann, K.; Wegner, C.; Wulff, C. Synthesis of Enantiopure Homoallylic Alcohols and Ethers by Diastereoselective Allylation of Aldehydes. *Chem.—Eur. J.* **1996**, 2, 1164–1172.
- 20 Tietze, L. F.; Wulff, C.; Wegner, C.; Schuffenhauer, A.; Schiemann, K. Mechanistic Investigations on the Highly Stereoselective Allylation of Aldehydes with a Norpseudoephedrine Derivative. *J. Am. Chem. Soc.* **1998**, 120, 4276–4280.
- 21 (a) Tietze, L. F.; Schiemann, K.; Wegner, C.; Wulff, C. Synthesis of Enantiopure Homoallylic Alcohols by a Highly Selective Asymmetric Allylation of Ketones. *Chem.—Eur. J.* **1998**, 4, 1862–1869. (b) Tietze, L. F.; Schiemann, K.; Wegner, C. Enantioselective Synthesis of Tertiary Homoallylic Alcohols via Diastereoselective Addition of Allylsilanes to Ketones. *J. Am. Chem. Soc.* **1995**, 117, 5851–5852.
- 22 Tietze, L. F.; Weigand, B.; Völkel, L.; Wulff, C.; Bittner, C. Synthesis of Enantiopure Homoallylic Ethers by Reagent Controlled Facial Selective Allylation of Chiral Ketones. *Chem.—Eur. J.* **2001**, 7, 161–168.
- 23 Tietze, L. F.; Kinzel, T.; Schmatz, S. Determination of the Origin of Stereoselectivity in Multiple-Transition-State Reactions Using DFT Calculations: Enantioselective Synthesis of Homoallylic Alcohols from Aliphatic Methyl Ketones via an Auxiliary-Mediated Allylation. *J. Am. Chem. Soc.* **2008**, 130, 4386–4395.
- 24 Tietze, L. F.; Wegner, C.; Wulff, C. New Improved Reagents for the Asymmetric Allylation of Ketones. *Synlett* **1996**, 471–472.
- 25 Tietze, L. F.; Hölsken, S.; Adrio, J.; Wegner, C. Facial-Selective Allylation of Methyl Ketones for the Asymmetric Synthesis of Homoallylic Ethers. *Synthesis* **2004**, 2236–2239.
- 26 (a) Tietze, L. F.; Görlitzer, J.; Schuffenhauer, A.; Hübner, M. Enantioselective Synthesis of the Chromane Moiety of Vitamin E. *Eur. J. Org. Chem.* **1999**, 1075–1084. (b) Tietze, L. F.; Görlitzer, J. Preparation of Enantiopure Precursors for the Vitamin E Synthesis. A Comparison of the Asymmetric Allylation of Ketones and the Sharpless Bishydroxylation. *Synlett* **1997**, 1049–1050.
- 27 Tietze, L. F.; Wegner, C.; Wulff, C. First Total Synthesis and Determination of the Absolute Configuration of the Stress Factor (+)-Hydroxymyoporone. *Chem.—Eur. J.* **1999**, 5, 2885–2889.
- 28 Tietze, L. F.; Völkel, L. Total Synthesis of the Macrolide Antibiotic 5,6-Dihydrocineromycin B. *Angew. Chem., Int. Ed.* **2001**, 40, 901–902.
- 29 Tietze, L. F.; Brazel, C. C.; Hölsken, S.; Magull, J.; Ringe, A. Total Synthesis of Polyoxygenated Cembrenes. *Angew. Chem., Int. Ed.* **2008**, 47, 5246–5249.
- 30 Tietze, L. F.; Völkel, L.; Wulff, C.; Bittner, C. Facial-Selective Allylation of Methyl Ketones for the Asymmetric Synthesis of alpha-Substituted Tertiary Homoallylic Ethers. *Chem.—Eur. J.* **2001**, 7, 1304–1308.